



BG95 LTE CAT M1/NB2

BG95 MiniPCIe LTE CAT M1/NB2 Technical Specifications & User Manual



Purpose of the Document

The purpose of this document is to explain the technical specifications and manual for using the miniPCIe BG95 LTE Cat M1/NB2 module.

Document History

Version	Author	Date	Description
A	5G HUB	09.19.2020	Initial Document

Table of Contents

Purpose of the Document	2
Document History	2
1 Package Content	4
2 General Description	5
2.1 Overview	5
2.2 Key Features.....	5
2.3 Data Rate.....	5
2.4 Interfaces	5
2.5 Software Features	5
2.6 Protocols	5
2.7 General Features.....	6
2.8 Approvals	6
2.9 Overview Diagrams	6
2.10 Functional Diagram	7
2.11 MiniPCIe PIN Diagram and Assignment	8
2.12 Pin Description	9
2.13 Operating Models	10
2.14 Airplane Mode	11
2.15 W_DISABLE#.....	11
2.16 PERST#.....	11
2.17 LED_WWAN#	11
2.18 WAKE#.....	12

1 Package Content

Package:

- miniPCIe for BG95-M3.

Download software:

Software can be downloaded from the following website:

<https://www.5ghub.us/download>

Software to download:

- QNavigatorV1.6 (in the folder \Tools).
- Quectel driver (in the folder \Driver).

Documentation:

- Quectel AT commands and GNSS commands manual (in the folder \Doc).

2 General Description

2.1 Overview

BG95 Mini PCIe is a series of LTE category M1/NB2 module adopting standard PCI Express Mini Card form factor (Mini PCIe). It is optimized specially for M2M and IoT applications and delivers 150Mbps downlink and 50Mbps uplink data rates. It provides data connectivity on LTE-FDD/GPRS/EGPRS networks, and supports half-duplex operation in LTE networks.

BG95 provides GNSS functionality to meet customers and supports Qualcomm® location technology (GPS, GLONASS, BeiDou, Galileo and QZSS). The integrated GNSS greatly simplifies product design, and provides quicker, more accurate and more dependable positioning.

A rich set of Internet protocols, industry-standard interfaces, and abundant functionalities (USB serial drivers for Windows 7/8/8.1/10, Linux, Android) extend the applicability of the module to a wide range of M2M applications such as industrial router, industrial PDA, rugged tablet PC, video surveillance and digital signage.

2.2 Key Features

- LTE category M1/NB1 module optimized for broadband IoT applications
- Worldwide LTE, and GSM/GPRS/EDGE coverage
- Standard PCI Express® MiniCard form factor (Mini PCIe) ideal for manufacturers to easily integrate wireless connectivity into their devices
- GNSS Gen8C Lite of Qualcomm. Multi-constellation GNSS receiver available for applications requiring fast and accurate fixes in any environment
- LTE FDD: B1/B2/B3/B4/B5/B8/B12/B13/B18/B19/B20/B25/B26/B28/b66/B85
- GSM 850/EGSM 900/DCS 1800/PCS 1900

2.3 Data Rate

- LTE
Cat M1: Max. 588 kbps (DL)/1119 kbps (UL)
Cat NB2: Max. 127 kbps (DL)/158.5 kbps (UL)
- GPRS:
Max. 107Kbps (DL)/85.6Kbps (UL)
- EDGE:
Max. 296Kbps (DL)/236.8Kbps (UL)

2.4 Interfaces

- USB 2.0 with High Speed up to 480Mbps
- 1.8V (U)SIM Interface
- NETLIGHT LED for network connectivity status indication
- UART × 3
- One main antenna (ANT_MAIN) and one GNSS antenna (ANT_GNSS) interfaces

2.5 Software Features

- USB Serial Driver:
Windows 7/8/8.1/10,
Linux 3.x(3.4 or later)/4.1~4.15
Android 4.x/5.x/6.x/7.x/8.x/9.x

2.6 Protocols

- Support PPP/TCP/UDP/SSL/TLS/FTP(S)/HTTP(S)/NITZ/PING/MQTT/LwM2M/CoAP/IPv6

protocols. Support PAP (Password Authentication Protocol) and CHAP (Challenge Handshake Authentication Protocol) protocols which are usually used for PPP connections

2.7 General Features

- Temperature Range: -35°C ~ +75°C
- Dimensions: 30.0mm x 51.0mm x 4.9mm
- Weight: Approx. 9.8g
- Mini PCIe Package
- Supply Voltage: 3.0V~3.6V, 3.3V Typ.
- 3GPP E-UTRA Release 14
- Bandwidth: 1.4/3/5/10/15/20MHz
- 3GPP TS 27.007

2.8 Approvals

- Carrier:
Vodafone (Global)
Deutsche Telekom/Telefónica (Europe)
Verizon/AT&T/T-Mobile/U.S. Cellular (North America)
Rogers/Bell*/Telus* (Canada)
SKT/KT*/LGU+* (South Korea)
NTT DOCOMO/SoftBank/KDDI (Japan)
- Regulatory:
GCF (Global)
CE (Europe)
FCC/PTCRB (North America)
IC (Canada)
Anatel (Brazil)
KC (South Korea)
NCC (Taiwan)
JATE/TELEC (Japan)
RCM (Australia/New Zealand)
FAC (Russia)
NBTC (Thailand)
ICASA (South Africa)
- Others:
RoHS Compliant
WHQL

2.9 Overview Diagrams

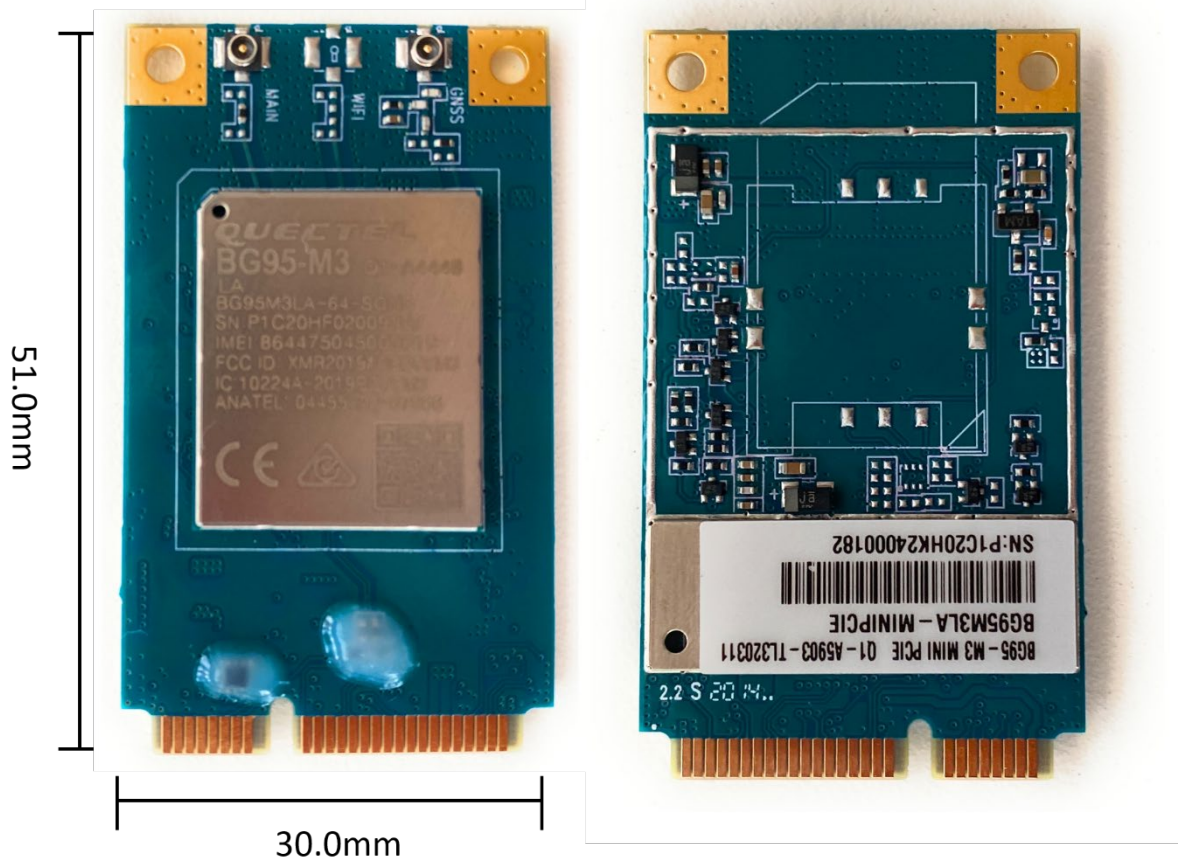

Figure 1. BG95 miniPCIe LTE Cat M1/NB1 module.

2.10 Functional Diagram

The following figure shows the block diagram of BG95 miniPCIe.

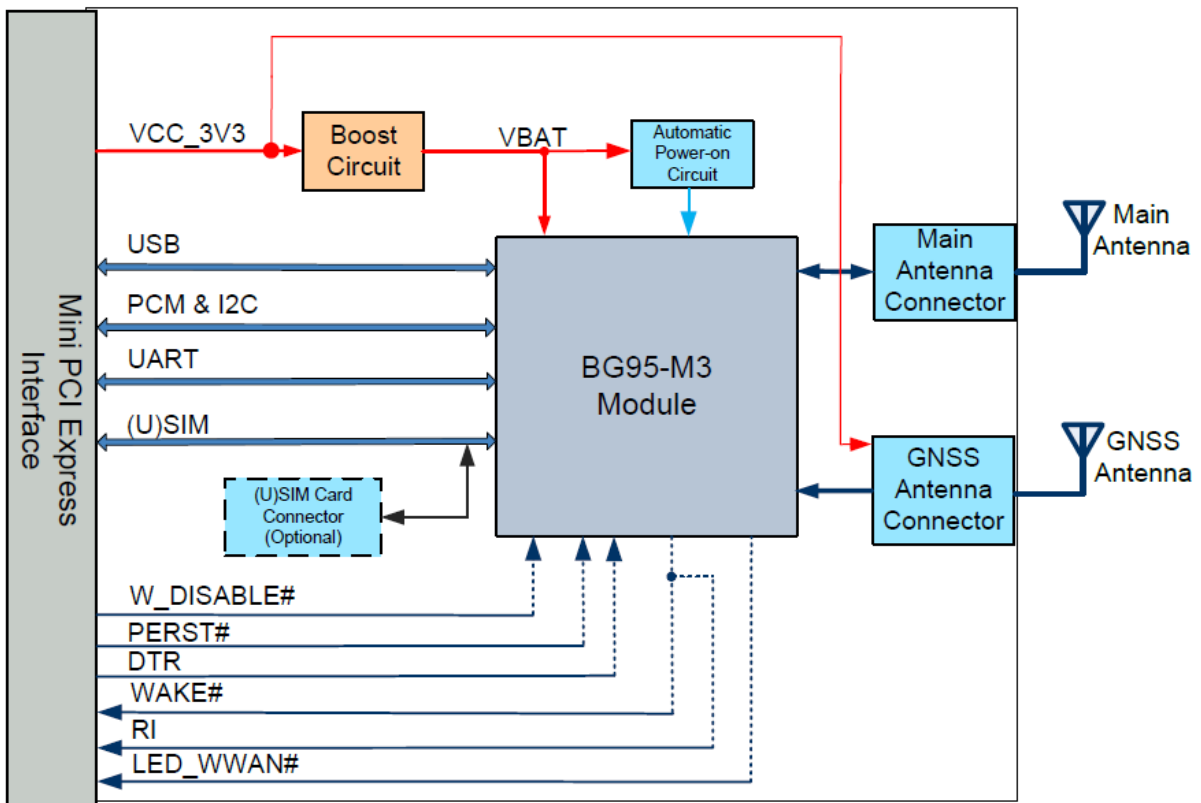

Figure 2. Physical characteristics.

2.11 MiniPCIe PIN Diagram and Assignment

The physical connections and signal levels of BG95 Mini PCIe comply with PCI Express Mini Card Electromechanical Specification.

- Power supply
- (U)SIM interface
- USB interface
- UART interfaces
- PCM and I2C interfaces
- Control and indication pins

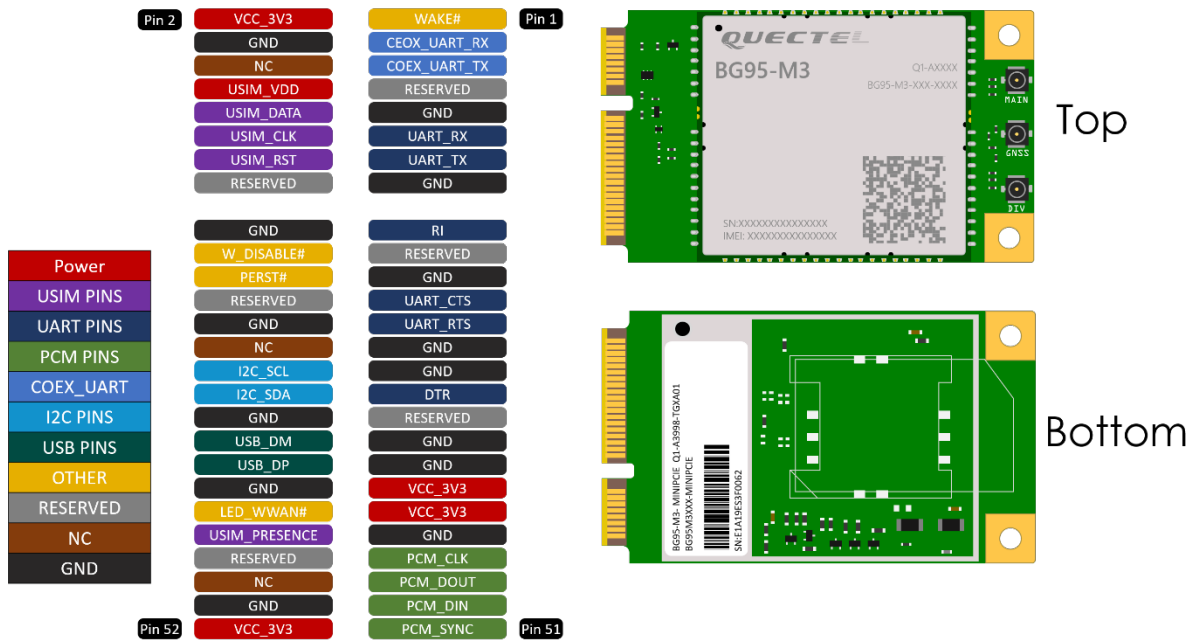

Figure 3. MiniPCle pin assignment.

2.12 Pin Description

Pin #	Pin Name	Pin Direction	Pin Functionality
1	NC		
2	VCC_3V3	I	3.0V~3.6V, typically 3.3V DC supply
3	NC		
4	GND		Mini card ground
5	NC		
6	NC		Not connected
7	RESERVED		Reserved
8	USIM_VDD	O	Power supply for the (U)SIM card
9	GND		
10	USIM_DATA	I	Data signal of (U)SIM card
11	UART_RX	I	UART receive data
12	USIM_CLK	O	Clock signal of (U)SIM card
13	UART_TX	O	UART transmit data
14	USIM_RST	O	Reset signal of (U)SIM card
15	GND		
16	RESERVED		
17	RI	O	Ring indication
18	GND		
19	RESERVED		

20	W_DISABLE#	I	Airplane mode control
21	GND		
22	PERST#	I	Fundamental reset signal
23	UART_CTS	I	UART clear to send
24	RESERVED		
25	UART_RTS	O	UART request to send
26	GND		
27	GND		
28	NC		
29	GND		
30	I2C_SCL	OD	I2C serial clock
31	DTR	DI	Sleep mode control
32	I2C_SDA	OD	OD I2C serial data
33	RESERVED		
34	GND		
35	GND		
36	USB_DM	IO	USB differential data (-)
37	GND		
38	USB_DP	IO	USB differential data (+)
39	VCC_3V3	I	3.0V~3.6V, typically 3.3V DC supply
40	GND		
41	VCC_3V3	I	3.0V~3.6V, typically 3.3V DC supply
42	LED_WWAN#	OC	LED signal for indicating the network status of the module
43	GND		
44	NC		(U)SIM card insertion detection
45	PCM_CLK	IO	PCM clock signal
46	RESERVED		
47	PCM_DOUT	O	PCM data output
48	NC		
49	PCM_DIN	I	PCM data input
50	GND		
51	PCM_SYNC	IO	PCM frame synchronization
52	VCC_3V3	PI	3.0V~3.6V, typically 3.3V DC supply

2.13 Operating Models

The following table briefly outlines the operating modes of the BG95.

Mode	Detail	
Normal Operation	Idle	Software is active. The module has registered on the network, and it is ready to send and receive data

	Talk/Data	Network connection is ongoing. In this mode, the power consumption is decided by network setting and data transfer rate.
Minimum Functionality Mode	AT+CFUN command can set the module to a minimum functionality mode without removing the power supply. In this case, both RF function and (U)SIM card will be invalid.	
Airplane Mode	AT+CFUN command or W_DISABLE# pin can set the module to airplane mode. In this case, RF function will be invalid.	

2.14 Airplane Mode

When the module enters airplane mode, the RF function will be disabled, and all AT commands related to it will be inaccessible.

2.15 W_DISABLE#

W_DISABLE# enables/disables the RF function (excluding GNSS). It is pulled up by default, and driving it low makes the module enter airplane mode. The pin function is disabled by default, and AT+QCFG="airplanecontrol",1 can be used to enable this function.

Airplane Mode Control (Hardware Method)

W_DISABLE#	RF Function Status	Module Operation Mode
High level (default)	RF enabled	Normal mode
Low level	RF disabled	Airplane mode

The RF function can also be enabled/disabled with **AT+CFUN=<fun>**, and the details are listed below.

Airplane Mode Control (Software Method)

AT+CFUN=<fun>	RF Function Status	Module Operation Mode
<fun>=0	RF and (U)SIM disabled	Minimum functionality mode
<fun>=1	RF enabled	Full functionality (normal mode)
<fun>=4	RF disabled	Airplane mode

2.16 PERST#

PERST# forces a hardware reset on the module. The module can be reset by driving PERST# low for 2–3.8 s and then releasing it.

2.17 LED_WWAN#

LED_WWAN# indicates the network status of the module. LED_WWAN# supports two indication modes which can be switched through **AT+QCFG="ledmode"**:

- **AT+QCFG="ledmode",0** (Default setting)
- **AT+QCFG="ledmode",1**

The following tables show the detailed network status indications of LED_WWAN#.

Indications of Network Status (AT+QCFG="ledmode",0, Default Setting)

Pin Status	Description
Flicker slowly (200 ms low/1800 ms high)	Network searching
Flicker slowly (1800 ms low/200 ms high)	Idle
Flicker quickly (125 ms low/125 ms high)	Data transfer is ongoing
Always low	Voice calling

Indications of Network Status (AT+QCFG="ledmode",1)

Pin Status	Description
Low Level (Light on)	Registered on network successfully
High-impedance (Light off)	-No network coverage or not registered -W_DISABLE# is at low level (airplane mode) - AT+CFUN=0 or AT+CFUN=4

2.18 WAKE#

WAKE# is an open collector signal which is similar to RI, but a host pull-up resistor and **AT+QCFG="risignaltype", "physical"** command are required. When a URC returns, a 120ms low level pulse will be outputted. The state of WAKE# is shown as below.